

DESIGN AND DEVELOPMENT OF A 1/3 SCALE VERTICAL AXIS WIND TURBINE FOR ELECTRICAL POWER GENERATION

Altab Hossain^{1*}, A.K.M.P. Iqbal¹, Ataur Rahman², M. Arifin¹ and M. Mazian¹

¹*Department of Mechanical Engineering, Faculty of Engineering, Universiti Industri Selangor, Malaysia*

²*Department of Mechanical Engineering, International Islamic University Malaysia, Malaysia*

Received 13 May 2007; received in revised form 3 November 2007; accepted 5 November 2007

Abstract:

This research describes the electrical power generation in Malaysia by the measurement of wind velocity acting on the wind turbine technology. The primary purpose of the measurement over the 1/3 scaled prototype vertical axis wind turbine for the wind velocity is to predict the performance of full scaled H-type vertical axis wind turbine. The electrical power produced by the wind turbine is influenced by its two major part, wind power and belt power transmission system. The blade and the drag area system are used to determine the powers of the wind that can be converted into electric power as well as the belt power transmission system. In this study both wind power and belt power transmission system has been considered. A set of blade and drag devices have been designed for the 1/3 scaled wind turbine at the Thermal Laboratory of Faculty of Engineering, Universiti Industri Selangor (UNISEL). Test has been carried out on the wind turbine with the different wind velocities of 5.89 m/s, 6.08 m/s and 7.02 m/s. From the experiment, the wind power has been calculated as 132.19 W, 145.40 W and 223.80 W. The maximum wind power is considered in the present study.

Keywords: Belt power transmission system; Reynolds number; wind power; wind turbine

© 2007 *Journal of Urban and Environmental Engineering (JUEE)*. All rights reserved.

* Correspondence to: Altab Hossain, Tel.: +6-03 3280 5122 Ext 7187; Fax: +6-03 3289 7335.
E-mail: altab75@unisel.edu.my

INTRODUCTION

Wind energy is the kinetic energy associated with the movement of atmospheric air. It has been used for hundreds of years for sailing, grinding grain, and for irrigation. Wind energy systems convert this kinetic energy to more useful forms of power. Wind energy systems for irrigation and milling have been in use since ancient times and since the beginning of the 20th century it is being used to generate electric power. Windmills for water pumping have been installed in many countries particularly in the rural areas.

Wind turbine is a machine that converts the wind's kinetic energy into rotary mechanical energy, which is then used to do work. In more advanced models, the rotational energy is converted into electricity, the most versatile form of energy, by using a generator (Fitzwater *et al.*, 1996). For thousands of years people have used windmills to pump water or grind grain. Even into the twentieth century tall, slender, multi-vaned wind turbines made entirely of metal were used in American homes and ranches to pump water into the house's plumbing system or into the cattle's watering trough. After World War I, work was begun to develop wind turbines that could produce electricity. Marcellus Jacobs invented a prototype in 1927 that could provide power for a radio and a few lamps but little else. When demand for electricity increased later, Jacobs's small, inadequate wind turbines fell out of use. The first large-scale wind turbine built in the United States was conceived by Palmer Cosslett Putnam in 1934; he completed it in 1941. The machine was huge. The tower was 36.6 yards (33.5 meters) high, and its two stainless steel blades had diameters of 58 yards (53 meters). Putnam's wind turbine could produce 1,250 kilowatts of electricity, or enough to meet the needs of a small town (Monett *et al.*, 1994). It was, however, abandoned in 1945 because of mechanical failure. With the 1970s oil embargo, the United States began once more to consider the feasibility of producing cheap electricity from wind turbines. In 1975 the prototype Mod-O was in operation. This was a 100 kilowatt turbine with two 21-yard (19-meter) blades. More prototypes followed (Mod-OA, Mod-1, Mod-2, etc.), each larger and more powerful than the one before.

Currently, the United States Department of Energy is aiming to go beyond 3,200 kilowatts per machine. Many different models of wind turbines exist, the most striking being the vertical-axis Darrieus, which is shaped like an egg beater (Fitzwater *et al.*, 1996). The model most supported by commercial manufacturers, however, is a horizontal-axis turbine, with a capacity of around 100 kilowatts and three blades not more than 33 yards (30 meters) in length. Wind turbines with three blades spin more smoothly and are easier to balance than those with two blades. Also, while larger wind turbines produce more energy, the smaller models are less likely to undergo major mechanical failure, and

thus are more economical to maintain. Wind farms have sprung up all over the United States, most notably in California. Wind farms are huge arrays of wind turbines set in areas of favorable wind production. A great number of interconnected wind turbines are necessary in order to produce enough electricity to meet the needs of a sizable population. Currently, 17,000 wind turbines on wind farms owned by several wind energy companies produce 3.7 billion kilowatt-hours of electricity annually, enough to meet the energy needs of 500,000 homes. A wind turbine consists of three basic parts: the tower, the nacelle, and the rotor blades. The tower is either a steel lattice tower similar to electrical towers or a steel tubular tower with an inside ladder to the nacelle. The first step in constructing a wind turbine is erecting the tower. Although the tower's steel parts are manufactured off site in a factory, they are usually assembled on site. The parts are bolted together before erection, and the tower is kept horizontal until placement. A crane lifts the tower into position, all bolts are tightened, and stability is tested upon completion. Next, the fiberglass nacelle is installed. Its inner workings main drive shaft, gearbox, and blade pitch and yaw controls are assembled and mounted onto a base frame at a factory (Hammons, 2004). The nacelle is then bolted around the equipment. At the site, the nacelle is lifted onto the completed tower and bolted into place. In addition, the aerodynamics of a wind turbine at the rotor surface is very much important in aerodynamic fields. The rotor axis is brought to a vertical orientation with a wind vane mounted on a control shaft to orientate the blades with changing wind direction. Using pitch regulation the rotor blades turn around their axis so that the aerodynamic characteristics of the blade and rotor are controlled. The rotor is yawed out of the wind which turns the rotor plane to follow the changing wind direction. The hub is connected to the rotor with rigid bolt connection and the rotational speed of the rotor is fixed relative to the frequency of the grid.

The future can only get better for wind turbines. The potential for wind energy is largely untapped. The total amount of electricity that could potentially be generated from wind in the United States has been estimated at 10,777 billion kWh annually (Keith, 2005). These new wind farms demonstrate how wind energy can help to meet the nation's growing need for affordable, reliable power. With continued government encouragement to accelerate its development, this increasingly competitive source of renewable energy will provide at least six percent of the nation's electricity by 2020. Research is now being done to increase the knowledge of wind resources. This involves the testing of more and more areas for the possibility of placing wind farms where the wind is available and strong. Plans are in effect to increase the life span of the machine from five years to 20 to 30 years, improve the efficiency of the blades, provide better controls, develop drive trains that last

longer, and allow for better surge protection and grounding. The United States Department of Energy has recently set up a schedule to implement the latest research in order to build wind turbines with a higher efficiency rating than is now possible (the efficiency of an ideal wind turbine is 59.3 percent (Milligan & Artig, 1999). That is, 59.3 percent of the wind's energy can be captured. Turbines in actual use are about 30 percent efficient). The United States Department of Energy has also contracted three corporations to investigate ways to reduce mechanical failure. This project began in the spring of 1992 and will extend to the end of the century. Wind turbines will become more prevalent in upcoming years. The turn of the century should see wind turbines that are properly placed, efficient, durable, and numerous. From the investigation of this wind turbine background, an H-type, vertical axis wind turbine has been designed and built in thermal Laboratory Universiti Industri Selangor that has the capability to self-start. In addition, this turbine has been designed to allow a variety of modifications such as blade profile and pitching to be tested. The first part of the design process, which included research, brainstorming, engineering analysis, turbine design selection, and prototype testing have been incorporated. Using data obtained through proper investigation results, the final full-scale turbine has been designed and built.

Wind turbines can be separated into two types based by the axis in which the turbine rotates namely horizontal axis wind turbine (HAWT) and the vertical axis wind turbine (VAWT). HAWT has difficulty operating in near ground, turbulent winds because their yaw and blade bearing need smoother, more laminar wind flows, difficult to install needing very tall and expensive cranes and skilled operators, downwind variants suffer from fatigue and structural failure caused by the turbulence and height can be a safety hazard for low-altitude aircraft. Other than that, the aerodynamics of a horizontal-axis wind turbine is complex. The air flow at the blades is not the same as the airflow far away from the turbine. The very nature of the way in which energy is extracted from the air also causes air to be deflected by the turbine. In addition, the aerodynamics of a wind turbine at the rotor surface includes effects that are rarely seen in other aerodynamic fields. A wide variety of VAWT configurations have been proposed. The Darrieus vertical type wind turbine is the most common and used extensively for power generation. However, the Darrieus turbine suffered from structural problems as well as a poor energy market.

To improve the performance of a wind turbine, this study has been concentrated on design and built an 1/3 scale H-type, vertical axis wind turbine that has the capability to self-start due to the wind flow and efficient performance of the VAWT that could lead to a change in the standard thinking of how wind energy is

harnessed, and may spur future VAWT design and research. The study on the enhanced performance of the wind turbine is also given by incorporating drag devices.

WIND TURBINE DESIGN

Theoretical analysis

The belt drive system consists of several parts of the belt drive calculation and the V-Type belt is considered in this study. Thus the main calculation that has been done at this system are angle of wrap for small and large pulley, belt length, pulley speed, the tension ratio and the power transmitted by the belt. The structure of the V-belt is shown in **Fig. 1**, which illustrates the main parts in V-belt such as the large pulley diameter indicated by the number 3 and the small pulley by the number 2 and the angle of wrap of large pulley indicated by θ_3 and small pulley by θ_2 . C indicates the centered radius between large and small pulleys.

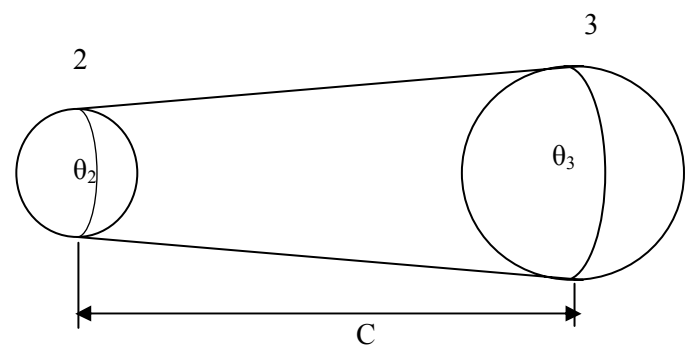

Fig. 1 The structure of the V-belt.

Angle of wrap for large pulley

Angle of wrap for large pulley is defined as (Joseph *et al.*, 2004)

$$\theta_3 = 180^\circ + 2 \sin^{-1} \frac{D_3 - D_2}{2C} \quad (1)$$

Using large pulley diameter D_3 as 30.48×10^{-2} m, small diameter D_2 as 5.08×10^{-2} m and the radius C as 0.3048 m in **Eq. (1)**, the angle of wrap for the large pulley is obtained as $\theta_3 = 229.25^\circ$.

Angle of wrap for small pulley

Angle of wrap for small pulley is defined as (Joseph *et al.*, 2004)

$$\theta_2 = 180^\circ - 2 \sin^{-1} \frac{D_3 - D_2}{2C} \quad (2)$$

Using the same values as mentioned above in **Eq. (2)**, angle of wrap for the small pulley is obtained as $\theta_2 = 130.75^\circ$.

Centered radius length

Centered radius length is defined as (Joseph *et al.*, 2004)

$$L = 2C + \frac{\pi}{2}(D_3 + D_2) + \frac{(D_3 - D_2)^2}{4C} \quad (3)$$

Using large pulley diameter D_3 of 30.48×10^{-2} m, small pulley diameter D_2 as 5.08×10^{-2} m and the centered radius C as 0.3048 m in **Eq. (3)**, the radius length is obtained as $L=1.221$ m.

Tension ratio tide side over slack side

Tension ratio of tide side over slack side is defined as (Joseph *et al.*, 2004):

$$\frac{T_1}{T_2} = \ln \left[\frac{(\mu \theta_3)}{2.3} \right] \quad (4)$$

where, the coefficient of belt friction μ is 0.25, θ_3 is the aforementioned angle of wrap of small pulley in radians (4 rad), T_1 is tension at tide side and T_2 is tension at slack side.

Using the values as mentioned above in **Eq. (4)**, tension ratio of tide side over slack side is obtained as $T_1/T_2 = 1.545$.

Tide side belt tension

Tension of tide side is defined as (Sorge, 1996)

$$T_1 = Wg \quad (5)$$

By choosing the total weight W of the upper part of turbine as 17 kg and adopting gravitational acceleration g as 9.81 m/s^2 in **Eq. (5)**, tension of tide side is obtained as $T_1 = 166.77 \text{ N}$.

Slack side belt tension

Using the value of T_1 in **Eq. (4)**, tension of slack side is obtained as $T_2 = 107.94 \text{ N}$.

Pulley velocity

Velocity of pulley is defined as (Joseph *et al.*, 2004)

$$V = \frac{\pi D_3 N}{60} \quad (6)$$

Power transmitted by the belt

The power transmitted by the belt is defined as (Joseph *et al.*, 2004)

$$P_B = (T_1 - T_2)V \quad (7)$$

Using tension at tide side T_1 as 166.77N, tension at slack side T_2 as 107.94N and pulley velocity V as 2.84 m/s in **Eq. (7)**, power transmitted by the belt is obtained as $P_B = 167.08 \text{ W}$.

Prototype design

The components of the 1/3 scaled vertical axis wind turbine are designed by using the CATIA software in the Structural Laboratory in Unisel and assembled together to predict the full scale. The wind turbine is a three bladed with tapered wing sections connected to the rotor of the generator and has been tested at an open hall. The corner sharp has been used as aerofoil for the wind turbine blade by producing a controllable aerodynamic force with its motion through the wind flow as shown in **Fig. 2**. The other main components that have been designed and used to construct the wind turbine are described in the following sections.

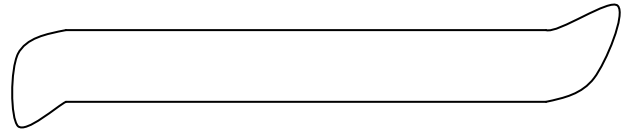

Fig. 2 The shape of Aerofoil with 139.7 mm chord.

Base and Base Table

The base material has been chosen as steel since it stands 6096 mm high and weighs 15 kg, and on its own the base does not support the torque and moments produced from the wind turbine, so a base extension and a connecting bracket have been designed. To connect the 4 sheets of steel bracket to the steel base a bottom bracket made of $38.10 \text{ mm} \times 762 \text{ mm}$ steel has been used. The $38.10 \text{ mm} \times 38.10 \text{ mm}$ structure provides quick assembly and disassembly of the turbine base structure.

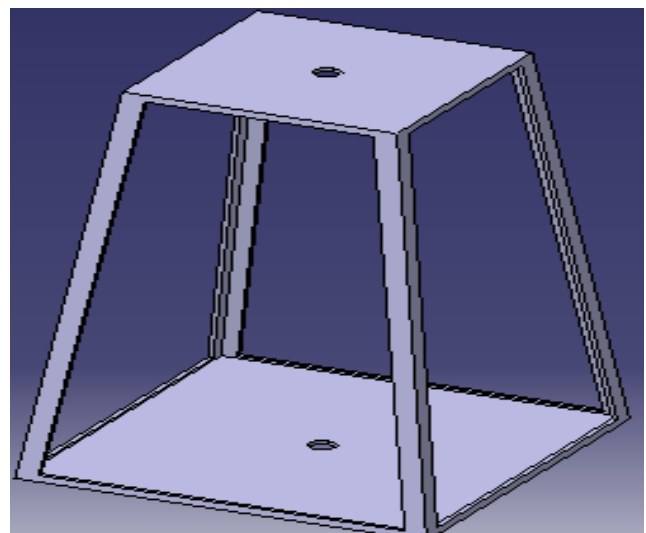

Fig. 3 Base table.

The bottom bracket requires four simple corner welds and flat head bolts welded in position that encourage quick assembly. Four sheets of 1219.20 mm

× 2438.40 mm × 19.05 mm have been used to construct a base extension that gives a larger footprint on which weights are placed. The main sheet is oriented with two sheets side-by-side, with two other sheets on top at 90 degrees rotation to the bottom two sheets. This creates a base table of 2438.40 mm × 2438.40 mm dimensions as shown in **Fig. 3**.

Shaft and Bearings

The shaft used in this design is the type of polishaft and its weight is 14 kg, being made from steel. The diameter of the shaft is 30 mm and its length is 2133.6 mm. Its surfaces are very soft and make the shaft rotation very smooth when attached to the bearing. Minimizing the required start-up torque is essential for the wind turbine to self-start and thus, the success of the project. The bearings that are used in the wind turbine design are not salvageable.

Bearings are very expensive, and for the particular setup two roller bearings have been used that are primarily centralized with the shaft. This combination provides the least amount of friction, while maximizing bearing life and maintaining safe operating conditions. The diameters of the bearings are 88 mm and weights 300 g each.

Support Arm and Drag Device

Steel is used for the three support radial arms to maintain a lightweight assembly with minimal inertial, moment, and centrifugal forces. The connecting arms provide a means to mount the blades to the center shaft. A drag device has been made from a lightweight plastic (casting plastic) and mounted to the main shaft. The length of the drag device is about 762 mm and width is 182.88 mm.

Wind Turbine Blade Design

The top and bottom of each blade is a 1066.8 mm × 139.7 mm × 50.8 mm deep rectangular section to allow for easier connections to the radial arms and passive pitching system. In this study the corner sharp has been selected as the shape of the blade for its very high capability to face the resistance of wind flow and faster rotation during the wind flow.

The final assembly of the wind turbine has been set at Thermal Laboratory in Universiti Industri Selangor and is shown in **Fig. 4**. There are 18 parts and 15 screws combined together in the assembly process. The shaft is connected to the main parts and to the alternator during the full assembly of this vertical axis wind turbine.

Experimental Procedure

The prototype of the Unisel wind turbine is installed at the Thermal Laboratory in Universiti Industri Selangor and a number of preliminary tests have been carried out

on the device, which has operated successfully. Before starting the operation, the battery terminal and alternator terminal are checked properly and it is connected with the lamp and switch. Then the wind turbine is allowed to rotate. Due to the rotation of the wind turbine blade voltage is produced and the connected lamps are turned on (**Fig. 5**).

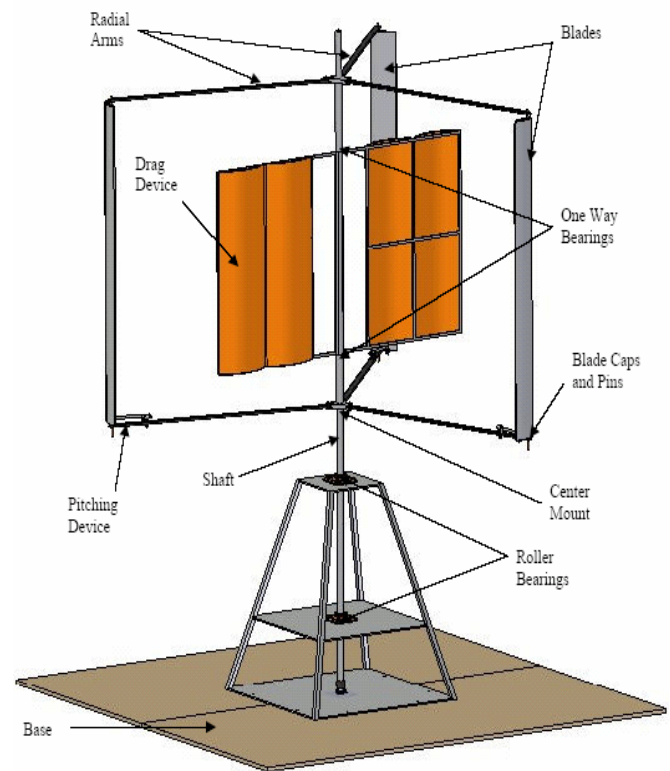

Fig. 4 Final assembly of the prototype wind turbine.

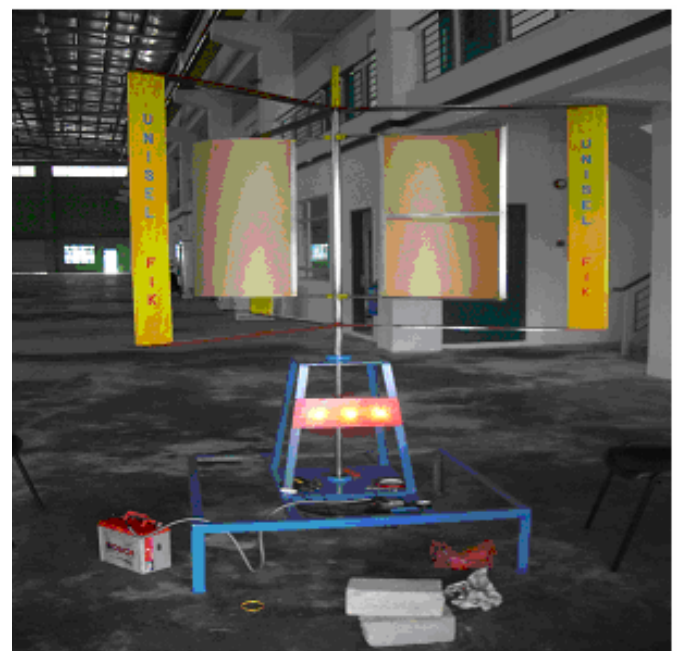

Fig. 5 Experiment of power generation with wind turbine.

Table 1. Free stream velocity and Reynolds number

| Serial Number | Free stream velocity (m/s) | Reynolds number |
|---------------|----------------------------|--------------------|
| 1 | 5.89 | 0.49×10^5 |
| 2 | 6.08 | 0.51×10^5 |
| 3 | 7.02 | 0.58×10^5 |

The produced voltage readings and the respective turbine rotations are recorded. The ambient pressure and temperature are recorded using the manometer and thermometer for the evaluation of air density in the Laboratory environment of Universiti Industri Selangor.

The power produced by the wind speed is also calculated which is shown in the specimen calculation section. The main test is performed at open hall in the Thermal Laboratory of Faculty of Engineering, UNISEL, where wind speeds are measured between 4 and 6 m/s, with gusts up to 7 m/s.

During the test, the turbine has been run based on the design, then the blades are opened and the wind has been propelled, and finally it has been checked about sufficient production of lift when the blades are closed. It has been seemed as though the turbine would slow down too much in the regions where lift is not produced thus the blades are kept opening up just to allow rotation. Next the blades have been opened to check the maximum attainable rotational speed in the drag position. In this position it is observed that there is plenty of windswept area to rotate the turbine.

Specimen calculation

Absolute pressure $p = 1.01 \times 10^5$ N/m² and temperature, $T = 38.5^\circ\text{C} = 311.5\text{K}$. Using equations of state for perfect gas the air density, ρ_∞ is 1.13 kg/m³ and is defined as (Bertin, 2002):

$$\rho_\infty = \frac{p}{RT} \tag{8}$$

where, pressure p is 1.01×10^5 N/m², temperature T is 311.5 K, and gas constant of air R is 287.05 Nm/kg K.

The air viscosity, μ_∞ is determined using the Sutherland’s equation (Bertin, 2002) described below

$$\mu_\infty = 1.458 \times 10^{-6} \frac{T^{1.5}}{T + 110.4} \tag{9}$$

where μ_∞ is the dynamic viscosity.

At T of 311.5 K, **Eq. (9)** gives value of μ_∞ of 1.90×10^{-5} kg/m s. Reynolds number based on the chord length is defined as (Anderson, 1996).

$$R_e = \frac{\rho_\infty v_\infty c}{\mu_\infty} \tag{10}$$

Using air density ρ_∞ of 1.13 kg/m³, free stream velocity v_∞ of 5.89 m/s; dynamic viscosity μ_∞ of 1.90×10^{-5} kg/m s and chord length c of 0.1397 m in **Eq. (10)**, Reynolds number is obtained as $Re = 0.49 \times 10^5$.

For the remaining velocities the corresponding Reynolds numbers are given in **Table 1**. For a rectangular blade, frontal surface area for a single surface is defined as (Bertin, 2002):

$$S = bc \tag{11}$$

For a wind turbine, total frontal surface area S_T is 1.145 m² and is defined as (Bertin, 2002):

$$S_T = (S_1)_T + (S_2)_T \tag{12}$$

where, the total frontal area for blade $(S_1)_T$ is 0.4482 m² and the total frontal area for drag surface $(S_2)_T$ is 0.6968 m².

Wind power of the turbine is defined as (Bench & Cloud, 2004)

$$P_{\text{wind}} = \frac{1}{2} \rho_\infty S_T v_\infty^3 \tag{13}$$

where, the density of air ρ_∞ is 1.130kg/m³, the total frontal area S_T is 1.145m², and wind velocity v_∞ is 5.89 m/s.

Putting the values into **Eq. (13)**, we have:

$$P_{\text{wind}} = \frac{1}{2} \times 1.130 \times 1.145 \times 5.89^3 \left[\frac{\text{kg}}{\text{m}^3} \times \text{m}^2 \times \left(\frac{\text{m}}{\text{s}} \right)^3 \right]$$

$$P_{\text{wind}} = 132.19 \text{ W}$$

For the remaining velocities corresponding wind power are given in **Table 2**.

RESULTS AND DISCUSSIONS

Experiments have been carried out at open hall UNISEL at the three different velocities of 5.89 m/s, 6.08m/s and 7.02 m/s. Based on the measurement of velocity the wind power for this prototype is calculated at the previous section and is given in **Table 2**. The calculated values for the Reynolds number in **Table 1** have been presented in the previous section.

The further understanding of the relationship between the variables measured as velocity as well as calculated wind power and Reynolds number from the test conducted has been discussed in term of graphs.

Table 2. Velocities and Corresponding wind power

| Serial No. | Velocities (m/s) | Wind power (W) |
|------------|------------------|----------------|
| 1 | 5.89 | 132.19 |
| 2 | 6.08 | 145.40 |
| 3 | 7.02 | 223.80 |

Reynolds number

The higher values in Reynolds number indicate the wind turbine has ability to produce more power due to increase in value of the wind velocity and this value is calculated and recorded in tests conducted at the wind velocity of 7.02 m/s.

The Aerofoil geometry

Selecting appropriate aerofoil to a 3-bladed vertical axis wind turbine is one of the most important design decisions. Different profiles provide various advantages and disadvantages that must be considered. However, the affection of this wind flow due to airfoils or blades is very small and the amount of the force that depends on the blade during the rotation has been ignored. In addition, the blade that has been designed and used in this model is not considered as NACA 0012 or NACA 0015 which are preferable in the low Reynolds number range, but the shapes selected in the current project still responded and acted with a very high durability and efficient functional to the shaft to rotate during the wind flow.

The Drag Devices geometry

The drag devices that have been used in current project provide external support to the blade by collecting the maximum amount of wind flow and initializing the rotation of the blade and the shafts. The drag devices are very sensitive to small amounts of the wind flow and it always causes the blades and shaft to rotate even the wind velocity is very small in magnitude at the considered location. During the test conducted on this model the wind has been blocked by one of the open drag, and diverted around the other. This is factorizing the net torque which drives the open drag around the shaft and induces rotation of the turbine, which leads to centrifugal forces. The rotational speed is increased until a critical point at which the turbine is moving fast enough to be driven by the lift forces. The opening/closing of drag mechanism is designed such that the centrifugal forces overcome the inertial forces and direct forces at this critical speed. In particular, the device has a very strong torque characteristic at low tip speed ratio, which means it is a self-starting. However, difficulties with commissioning of the torque measurement and control systems have delayed the acquisition of definite test data to date.

Turbine feasibility comparisons

The calculated wind power from the current 1/3 scale wind turbine and the overall comparisons of the existing turbine according to the type of connection used and the estimated costs are shown in **Table 3**.

The University of Wollongong project has produced the maximum wind power which of 700 W using a

Table 3. Feasibility comparison of different wind turbine

| University Research | Type of connection | Wind velocity (m/s) | Power (W) | Cost (US\$) |
|---------------------|--------------------|---------------------|-----------|-------------|
| Wollongong | Gearing System | 25 | 700 | 820 |
| Griffith | Gearing System | 20 | 550 | 673 |
| UNISEL | Belt & Pulley | 6 | 167 | 253 |

gearing system and Griffith University has produced electrical power of 550 W using a similar system (Cooper & Kennedy, 2003; Kirke, 2003). The tested prototype in current project has been produced 167 W using the belt and pulley system. According to the evaluation of wind velocities, the current model can exceed the existing models if the wind velocity is increased. The current prototype would be capable to produce 567.33 W when the wind velocity increases to 20 m/s and 709.17 W when the wind velocity increases to 25 m/s. This overall comparison presents evidence that the current prototype, which uses the pulley and belt systems, is more feasible than the other models that uses the gearing system in terms of cost and to produce power.

Conclusion

The conclusions drawn from this investigation are as follows:

- Wind power produced by the prototype increases maximum of 1000 W with the increase of maximum wind velocity of about 12 m/s.
- From the investigation there is evidence that the current prototype is capable to produce 567.33 W when the wind velocity increases to 20 m/s and 709 W when the wind velocity increases to 25 m/s.

Nomenclature

| Symbol | Meaning | Unit |
|---------------|----------------------------|----------------------|
| p | Absolute pressure | (N/m ²) |
| T | Temperature | (K) |
| R | Gas constant | (Nm/kg K) |
| ρ_∞ | Air density | (kg/m ³) |
| μ_∞ | Air viscosity | (kg m/s) |
| v_∞ | Free stream velocity | (m/s) |
| c | Chord length | (m) |
| Re | Reynolds number | (Dimensionless) |
| B | Blade height | (m) |
| S_1 | Blade frontal surface area | (m ²) |
| S_2 | Drag device frontal area | (m ²) |
| S_T | Total frontal area | (m ²) |
| P_{wind} | Wind power | (W) |

Acknowledgment The authors are grateful for the support provided by financial assistance from the Universiti Industri Selangor, and faculty of Engineering for the overall facilities.

REFERENCES

- Anderson, J.D.Jr. (1999) Aircraft Performance and Design. McGraw Hill Companies Inc., U.S.A.
- Bench, S.E., Cloud, P.K. (2004) The Measure, Predict and Calculate the Power response of an Operating Wind Turbine. 1st Ed., London, Jepson Pub, 366 p.
- Bertin, J. J. (2002) Aerodynamics for the Engineer. New Jersey, Prentice Hall, Inc., U.S.A.
- Cooper, P., Kennedy, O. (2003) Development and Analysis of a Novel Vertical Axis Wind Turbine. Bachelor. Thesis, University of Wollongong, NSW 2522, Australia.
- Fitzwater, L.M., Cornell, C.A., Veers, P.S. (1996) Using Environmental Contours to Predict Extreme Events on Wind Turbines. *Wind Energy Symp.*, AIAA/ASME, **9**, 244–258.
- Hammons, T.J. (2004) Technology and Status of Developments in Harnessing the World's Untapped Wind-Power Resources. *Electricity Power Components and Systems*. No.12, p. 32.
- Joseph, E.S, Charles, R.M, Richard, G.B. (2004) *Mechanical Engineering Design*. 7th Ed., United State of America. p. 1030.
- Keith, David W. (2005) The Influence of Large-Scale Wind Power on Global Climate. Proc. National Academy of Sciences, Washington D.C, Vol. 101, pp. 12–56.
- Kirke, B.K. (2003) Evaluation of self-starting vertical axis wind turbines for stand alone applications. PhD Thesis, Griffith University, Australia.
- Milligan, M.R. & Artig, R. (1999) Choosing Wind Power Plant Locations and Sizes Based on Electric Reliability Measures Using Multiple-Year Wind Speed Measurements. *National Renewable Energy Laboratory*, **8**, 52p.
- Monett, G., Poloni, C. & Diviacco, B. (1994) Optimization of wind turbine positioning in wind farms by means of large development. *J. of Wind Engng and Ind. Aerod* **23**(4), 105–16
- Sorge, F. (1996) A qualitative-quantitative approach to v-belt mechanics. ASME, *J. of Mechanical Design* **118**(8).