

METHOD OF DETERMINING THE ORIFICE AREA OF VALVE HEAD LOCKING PAIRS OF WATER FITTINGS

Alexandre P. Svintsov, Serge A. Mukarzel and Makhmud Kharun*

Department of Civil Engineering, Peoples' Friendship University of Russia, St. Orjonikidze 3, Moscow-115419, Russia

Received 09 March 2015; received in revised form 26 May 2016; accepted 10 June 2016

Abstract:

One of the important tasks when designing the water fittings is to calculate the orifice area of locking pair for passing the calculated water flow at a calculated pressure. The method of determining the orifice area with smoothly changing shape based on the piecewise-element method is proposed. This method is characterized by a comparative simplicity and sufficient accuracy for engineering calculations to determine the orifice area of the disk type locking pairs for the valve head. The proposed method allows us to determine the required size of the orifice area for passing the calculated water flow and also to determine the water flow rate depending on the opening level of orifice. The authors carried out the necessary calculations and manufactured ceramic disk type locking pairs by using the proposed method. Bench tests of water fittings with valve heads those are having orifices with smoothly changing shapes (in the form of bent blob) showed that water flow is changing almost in proportional to the tap opening. This method can be used not only for the designing of the water fittings and also for the shut-off valves of various purposes.

Keywords: Water fittings, Valve head, Water flow, Locking pair, Piecewise-element method

© 2016 Journal of Urban and Environmental Engineering (JUEE). All rights reserved.

* Correspondence to: Makhmud Kharun. E-mail: miharun@mail.ru

Introduction

Rational and efficient use of fresh water has its basic starting with the consumers in residential buildings. In this case one of the factors of economical use of tap water is the flow characteristic of water fittings.

Currently piston type valve head can be considered as decreasing of use. Water fittings for water supply in buildings are mainly equipped with valve heads with disk type flat locking pares. The valve heads with flat locking pares and with semicircular orifices work at high wear resistance almost without water leakage but they have low regulatory capacity. More effective for economical use of water are locking pairs with smoothly changing shape of orifice (like a bent blob).

One of the important tasks when designing the hydraulic path of water fittings is to determine the required orifice area of locking pair that allows calculating the water flow at the calculated pressure.

To solve this task we have developed the method of calculation to determine the area of geometric figure based on piecewise-element method.

Proposed method is comparatively simple in use and it allows defining the orifice area for passing the calculated water flow as well as to determine the geometric parameters of the constructed water fittings.

Bench tests of the water fittings that were designed according to the presented method of locking pairs have showed a high regulatory capacity of valve head of such structure.

Analysis of stated issue

Determination of the orifice area of locking pair is one of the most responsible elements in designing of the water fittings for water supply in buildings.

Calculation and design issues of hydraulic systems of different purposes are presented in textbooks (Cengel & Cimbala, 2006; Gusev, 2014) where the main attention is paid to determination of local resistance coefficients and their dependence on the orifice shape and hydraulic path. In these information sources the classical orifice types are considered: circle, semicircle and sector. But orifices with smoothly changing shape are not considered.

Research of Svintsov *et al.* (2010) presents the method of designing the flat valve head and it also made a brief comparative analysis of the hydraulics of orifices: circle, sectors, smoothly changing shape. However the method of determining the orifice area with smoothly changing shape is not presented sufficiently. It constrains the possibilities of designing the water fittings valve with flat locking elements.

Methods of research and equipment

The piecewise-element method of calculation is used to determine the orifice area with smoothly changing shape. The orifice areas for disk type locking pairs to pass the

minimum water flow of 0.07 l/sec at the pressure of 0.05 MPa in front of water fittings were calculated on the basis of the developed method. The value of the calculated water flow is determined by the formula (Cengel & Cimbala, 2006; Gusev, 2014):

$$q = \mu \omega \sqrt{2gH} \quad (1)$$

where μ – flow coefficient; ω – open area of orifice at locking pair; g – free fall acceleration; H – pressure in front of water fittings.

The experimental test of valve head that is equipped with disk type flat locking pair with smoothly changing shape of orifice was performed on a laboratory bench with the possibility to create and adjust the static pressure in front of water fittings from 0 to 1.0 MPa. Valve type faucets were taken for study. The valve head was equipped with the flat locking element with orifice with smoothly changing shape.

Rotameters of Ø15 mm and Ø40 mm with an error of not more than $\pm 2.5\%$ for the upper values were used to determine the flow rate of water. Water flow below the detection limit of rotameters was determined by using the measuring container of 1 liter. The chronometer with an accuracy of 0.1 seconds was used to determine the duration of filling a measuring container.

The water flow measurement was performed at the pressures of 0.05, 0.1, 0.5 and 0.6 MPa with gradual opening of a faucet. The flow changes were carried out by rotating the handle of valve head at the angle from 0° to 180° with steps of 10° . The rotation angle of handle was determined by a circular scale with a scale of 1° . A measurement quantity in front of a water fitting at each step of pressure was made according to the plan of experiment to get the statistically significant results with reliability of 0.95. The mathematical processing of the experimental data was carried out on the basis of theory of probability and mathematical statistics (Gmurman, 2014; Mendenhall *et al.*, 1990).

Using the piecewise-element method allowed us to develop the method for determining the calculated orifice area with smoothly changing shape for disk type flat locking pairs.

Using the specified devices, elements and methods of research allowed us to obtain the statistically significant and reliable data of water flow changes through the water fittings that are equipped with the flat locking pair with orifice of a new form.

Results and discussion

The water fittings of building plumbing system are usually equipped with the valve heads with disk type flat locking pairs made of ceramic or cermet. These locking pairs are made with orifice in the form of semicircle or sectors. The valve heads with flat locking pares of the specified type work at high wear resistance almost without unprompted leakage of water but have a low regulatory capacity. A low regulatory capacity appears

when consumer spends a lot of time to get the required water flow with a desired temperature (if there is a hot water supply system). It leads to a wasteful (without use) water loss in the process of water consumption and to an additional cost to pay for them.

Using of valve heads with the orifice with smoothly changing shape is more effective for careful use of water (Fig. 1).

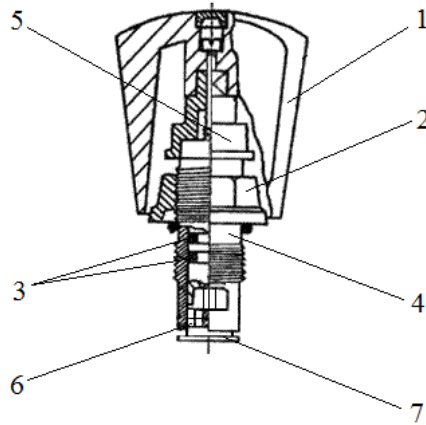

(a) valve head

1 - handle; 2 - nut; 3 - spindle sealing; 4 - spindle; 5 - body; 6 - locking pair of ceramic disks; 7 - rubber gasket

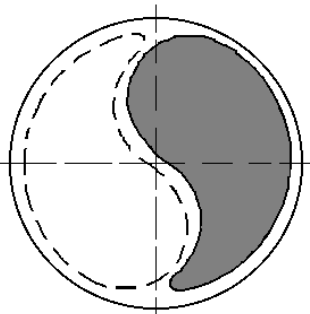

(b) orifice with smoothly changing shape

Fig. 1 Valve head with a disk type locking pair.

This shape allows the orifice to obtain the linear changes of water flow depending on the degree of faucet opening. Proportional changes of the water flow allow spending less time to adjust and thereby significantly reduce wasteful water loss. Reducing the wasteful water loss of consumers enables the society to use the water resources more efficiently.

One of the most important elements of designing the locking pair of valve head is to define the orifice area that is required to pass the required water flow at a specific pressure. If the locking pair with orifice is in the form of semicircle or sectors than it is not difficult to solve this task. If the orifices are with smoothly changing shape than the task of determining the area is based on the specially developed method that is proposed by authors for designing the locking pair of any purpose and with different flow rate characteristics. The developed method allows determining the orifice area with smoothly changing shape for a specified geometric parameters and also to determine the geometric parameters of known orifice area that are required to

pass a specified flow rate at a specific pressure. For convenient formation of mathematical idea the form of orifice (Fig. 1b) is advisable to present in a calculation scheme (Fig. 2).

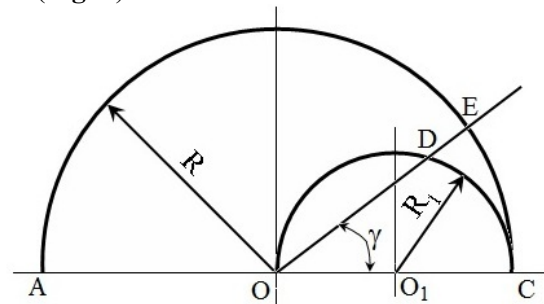

Fig. 2 Calculation scheme of shape of orifice of locking pair with smoothly changing shape.

Outer arc CA with orifice radius R relative to the center O is described by the following equation in parametric form:

$$\begin{aligned} X(\alpha) &= R \cos(\alpha) \\ Y(\alpha) &= R \sin(\alpha) \end{aligned} \quad (2)$$

where α changes from γ to π (γ – angle between the central axis of the disk and the ray emerging from the center O).

Straight line AO is described by a parametric form:

$$y(x) = 0 \quad (3)$$

where x changes from $-R$ to 0 .

Concave arc OC with radius R_1 from the center O_1 is described by the equation in parametric form:

$$\begin{aligned} X_1(\alpha_1) &= R_1[\cos(\alpha_1) + 1] \\ Y_1(\alpha_1) &= R_1 \sin(\alpha_1) \end{aligned} \quad (4)$$

where α_1 – angle, changes from 0 to π .

Maximum orifice area of locking pair (Fig. 2) is determined by the formula:

$$\omega_p^{\max} = S - S_1 \quad (5)$$

where S – area of the shape ACO ; S_1 – area of the shape ODB formed by radius R_1 (Fig. 4).

$$S = \frac{\pi R^2}{2} \quad (6)$$

where R – outer radius of the arc of orifice, $R = 0.8R_D$, R_D – radius of disk.

$$S_1 = \frac{\pi R_1^2}{2} \quad (7)$$

where R_1 – inner radius of the arc of orifice.

While designing a disk type valve head with smoothly changing orifice there can be several options of geometric formation. For illustration purposes we can

consider the case with the proviso that $\begin{cases} OO_1 = R_1 \\ 2R_1 \leq R \end{cases}$

(Fig. 3).

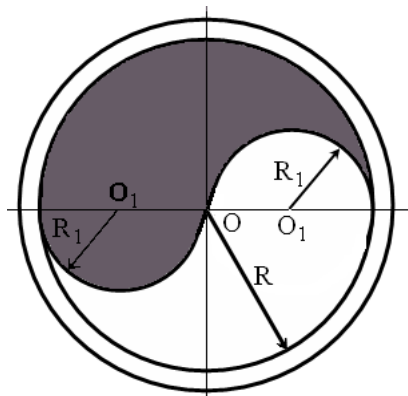

Fig. 3 Calculation scheme of orifice.

Orifice area of the locking pair is determined by the formula:

$$\omega_p = S^{OEC} - S^{ODB} - S_1 \quad (8)$$

where S^{OEC} – area of sector OEC formed by radius R (Fig. 4):

$$S^{OEC} = \frac{R^2 \gamma}{2} \quad (9)$$

where γ – angle of rotation of the handle of valve head, changes from 0 to π ; S^{ODB} – area of figure ODB (Fig. 4), changes from 0 to $\pi/2$:

$$S^{ODB} = S^{ODO_1} + S^{O_1DB} \quad (10)$$

where S^{O_1DB} – area of sector O_1DB (Fig. 5):

$$S^{O_1DB} = \frac{R_1^2 \beta}{2} \quad (11)$$

where β – angle O_1DB , $\beta = 2\gamma$;

S^{ODO_1} – area of triangle ODO_1 (Fig. 5):

$$S^{ODO_1} = \frac{R_1^2}{2} \sin \beta \quad (12)$$

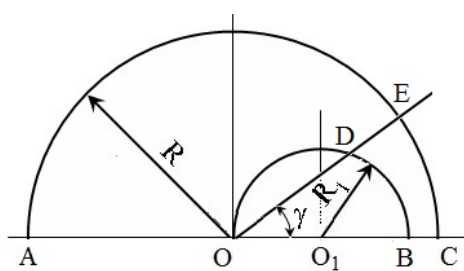

Fig. 4 Shape of orifice.

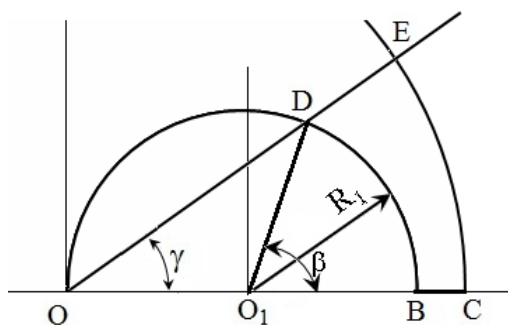

Fig. 5 Scheme to determine the orifice area.

Using Eqs (7), (9), (10), (11) and (12) in the Eq. (8):

$$\omega_p = \frac{R^2 \gamma}{2} - \frac{\pi R_1^2}{2} \left(\gamma > \frac{\pi}{2} \right) - \left(R_1^2 \gamma + \frac{R_1^2 \sin 2\gamma}{2} \right) \left(\gamma \leq \frac{\pi}{2} \right) \quad (13)$$

The Eq. (13) allows defining the parameters of orifices of disk type locking pairs for valve heads of any water fittings. In this case there are two possible ways to resolve the task:

- determine the orifice area on the basis of available geometric parameters;
- determine the geometric parameters of orifice while specifying the desired orifice area.

The authors have calculated the orifice area and geometrical parameters according to the proposed method. The experimental models were manufactured and tested according to calculation. While designing the locking pair with smoothly changing orifice the main attention was paid to ensure the minimum water flow when a tap is fully open and it is at a pressure of 0.05 MPa. The changes in flow characteristics of locking pair that were calculated by the developed method is shown in Fig. 6.

It was experimentally established that at the pressure of 0.05 MPa when the tap is fully open the water flow is not below the calculated minimum value. During the opening of a tap the water flow is changing almost linearly at all pressures. It indicates a high regulatory capacity of the valve heads with the flat locking pairs with smoothly changing orifices. Linear change of water flow allows spending a little time to adjust the required water flow with the desired temperature with the minimum wastage that is unavoidable in water consumption.

Researches of Svintsov & Kvartenko (2008) and Svintsov *et al.* (2011) have established that the wasteful water loss in multistoried residential buildings is 15–18% of water consumption because of the low regulatory capacity of water fittings. Considering that the wasteful water loss is an integral part of water consumption it can be assumed with a probability of 0.87–0.94 that for a family of three persons the reduction in water consumption is 12–15% per month *ceteris paribus* comparing to the valve head that is equipped with a locking pair with orifice in the form of semicircle or sectors.

Conclusion

As a result of theoretical and experimental studies the method of determining the orifice area with smoothly changing shape in the form of “bent blob” for a flat locking pair of valve type water fittings is proposed. The proposed method allows defining the orifice area for passing the calculated water flow at the calculated pressure. The method also allows determining the water flow at the certain pressure depending on the opening of orifice.

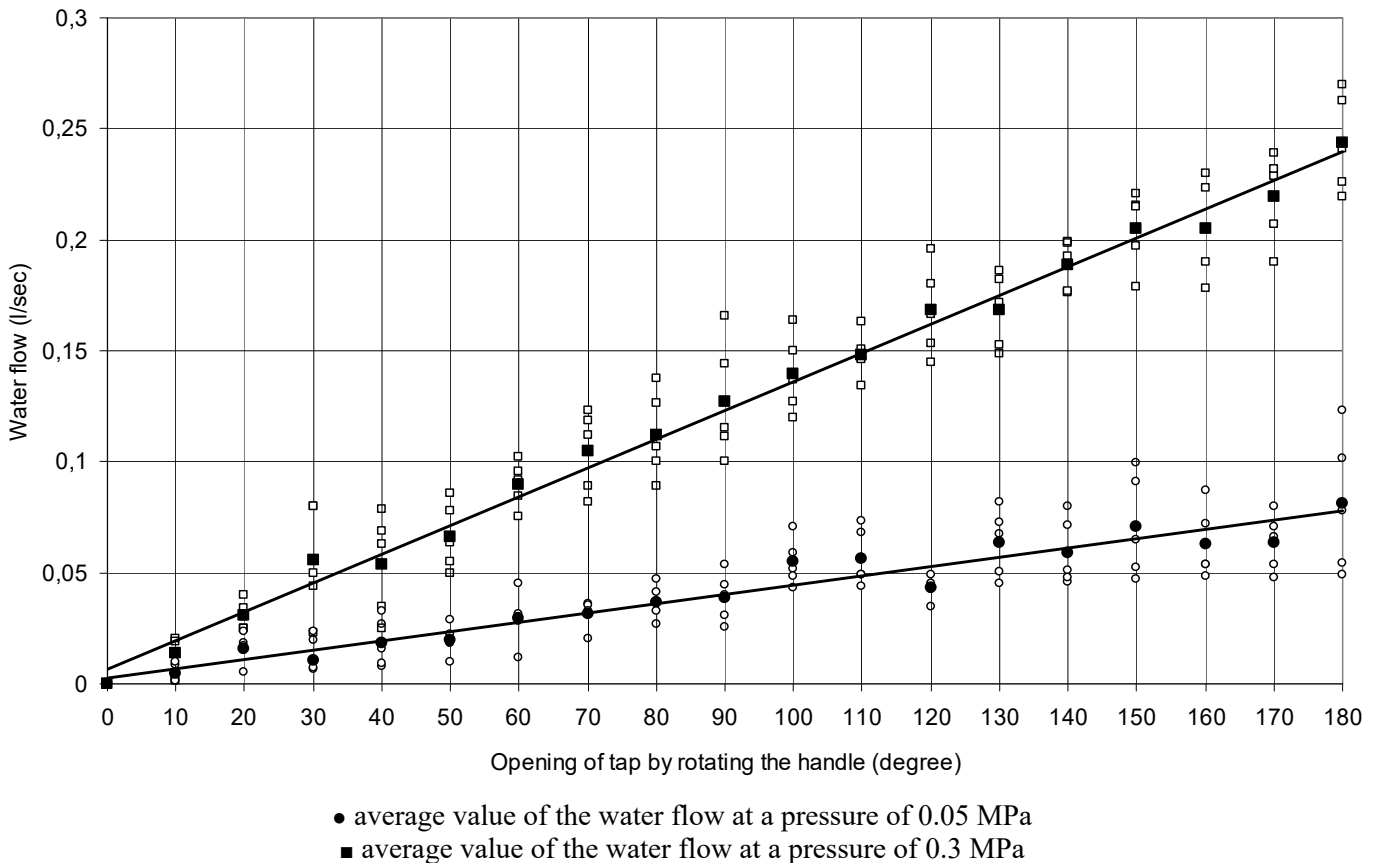

Fig. 6 Water flow during the opening of a tap at different pressures in front of a tap.

The bench tests of water fittings with a locking pairs that were calculated by the proposed method showed high regulatory capacity and linear changes of water flow depending on the tap opening level.

Verification while operating has showed high water saving efficiency of water fittings with the orifices that were defined by the proposed method of its area calculation. For a family of three persons the water savings are 12–15% per month comparing to fittings that are equipped with locking pairs in the form of semicircle or sectors.

References

- Cengel A.Y., Cimbala J.M. (2006) *Fluid Mechanics: Fundamentals and Applications*. McGraw-Hill, New York, USA.
- Gusev A.A. (2014) *Hydraulics: Theory and Practice - A Textbook for University Students of Technical Professions. 2nd Edition*. Publishing House "Yurait", Moscow, Russia.
- Svintsov A.P., Mukarzel S.A., Suchenko V.N., Glebov E.A. (2010) Design Technique for Dimensioning an Orifice of the Flat Valve of a Faucet Head. *Water Supply and Sanitary Technique*, **4**, 40–42.
- Gmurman V.E. (2014) *Theory of Probability and Mathematical Statistics. 12th Edition*. Publishing House "Yurait", Moscow, Russia.
- Mendenhall W., Wackerly D., Scheaffer R. (1990) *Mathematical Statistics with Applications* PWS-KENT Publishing Company, USA.
- Svintsov A.P., Kvarenko V.S. (2008) Water Consumption and Water Supply in the Housing. *Safety of Livelihood*, **10**, 35–38.
- Svintsov A.P., Suchenko V.N., Glebov E.A., Tami Al-Harami. (2011) Rational Use of Water in Residential Buildings. *Housing Construction*, **3**, 41–43.